

Description

- 1.6x0.81x0.65mm physical size
- Solder-free design
- Designed to UL248-1
- RoHS compliant, Halogen free and Lead-free



Dimensions

(Unit: mm)

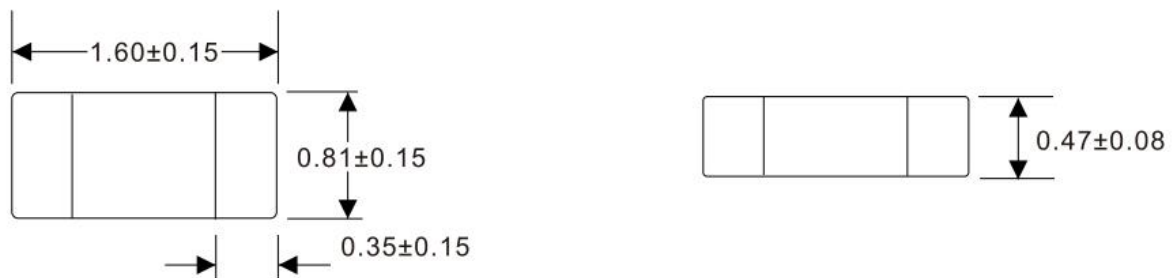

Specifications

Part No.	Rated Voltage (Vdc)	Rated Current (A)	Breaking Capacity (A)	Typical Cold Resistance (mOhms)	Typical Voltage Drop (mV)	Typical Pre-Arcing I ² t (A ² Sec)	Alpha Mark
HTF0603. 025	63 32	0.25	50A	3100	1435	0.0012	D
HTF0603. 0375		0.375		1600	1250	0.0028	E
HTF0603. 050		0.5		1000	750	0.005	F
HTF0603. 075		0.75		440	550	0.015	G
HTF0603. 100		1		240	310	0.035	B
HTF0603. 150		1.5		125	250	0.080	H
HTF0603. 200		2.0		68	170	0.16	K
HTF0603. 250		2.5		52	200	0.29	L
HTF0603. 300		3		34	155	0.32	O
HTF0603. 350		32		3.5	22	130	0.54
HTF0603. 400	4.5		20	100	0.95	S	
HTF0603. 500	5		13	95	1.80	T	
HTF0603. 600	6		8.5	80	2.9	V	
HTF0603. 700	7		6.5	80	3.5	X	
HTF0603. 800	8		5.3	75	4.8	Z	

DC Interrupting Rating (Measured at rated voltage, time constant of less than 50 microseconds, battery source)

DC Cold Resistance are measured at <10% of rated current in ambient temperature of 25 degrees

Typical Pre-arcing I²t are measured at 10In Current

For fuse below 1A, the color of glass coating is Blue; for 1A and above, it's Green.

Electrical Characteristics

Rated Current	1.0In	2.0In	2.5In	3.5In
250mA~750mA	4.0 hour min	-	-	5.0 sec max
1~5A	4.0 hour min	1.0 sec-60.0sec	5.0 sec max	-
6~7A	4.0 hour min	1.0 sec-60.0sec	-	-
8A	4.0 hour min	-	5.0 sec max	-

Installation Recommendations

1 Wave Soldering Paameters

Reflow Conditon		Pb-free assembly
Pre Heat	- Temperature Min ($T_{s(min)}$)	150°C
	- Temperature Max ($T_{s(max)}$)	200°C
	- Time (Min to Max) (t_h)	60 - 120 seconds
Average Ramp-up Rate (Liquidus Temp (TL) to peak)		3°C/second max.
TS(max) to TL - Ramp-up Rate		5°C/second max.
Reflow	- Temperature (TL) (Liquidus)	217°C
	- Temperature (tL)	60 - 150 seconds
Peak Temperature (T_p)		260+0/-5°C
Time within 5°C of actual peak Temperature (t_p)		30 seconds
Ramp-down Rate		6°C/second max
Time 25°C to peak Temperature (T_p)		8 minutes max.
Do not exceed		260°C

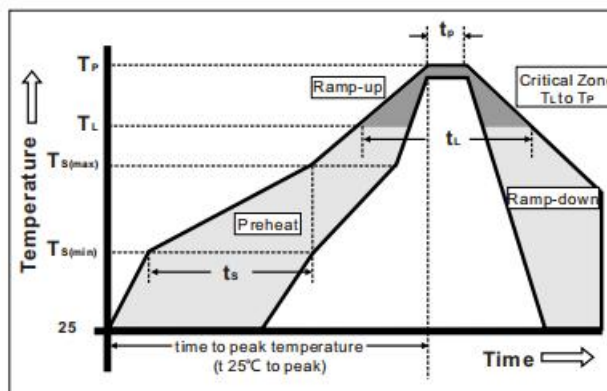

Solder Pot Temperature: 260°C max
Solder Dwell Time: 10 Seconds max

2 Hand-Solder Parameters

Solder Iron Temperature: 280±5° C
Heating Time: 5 Seconds min
Generally, hand-soldering is not recommended

Part Numbering System

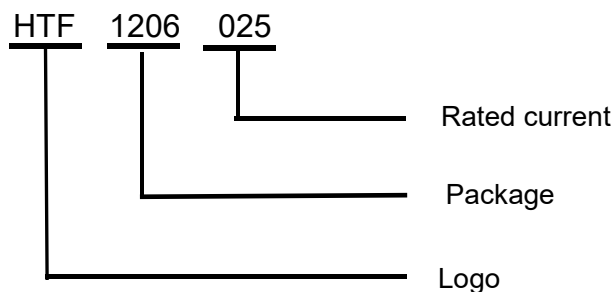

Product Characteristics

Materials	Body: Ceramic Terminators: Silver over-plated with tin Element: Alloy(Ag,Cu,Zn) Cover Coat: Glass
Operatng Temperature	-55°C to 125°C Consult temperature rerating curve chart.
Thermal Shock	300 cycles -55°C to 125°C
Humidity	MIL-STD-202F, Method 103B, Condition D
Vibraton	Per MIL-STD-202F, Method 201A
Insulaton Resistance (Afer Opening)	Greater than 10,000 ohms
Resistance to Soldering Heat	MIL-STD-202G, Method 210F, Condition D

Time Current Curve

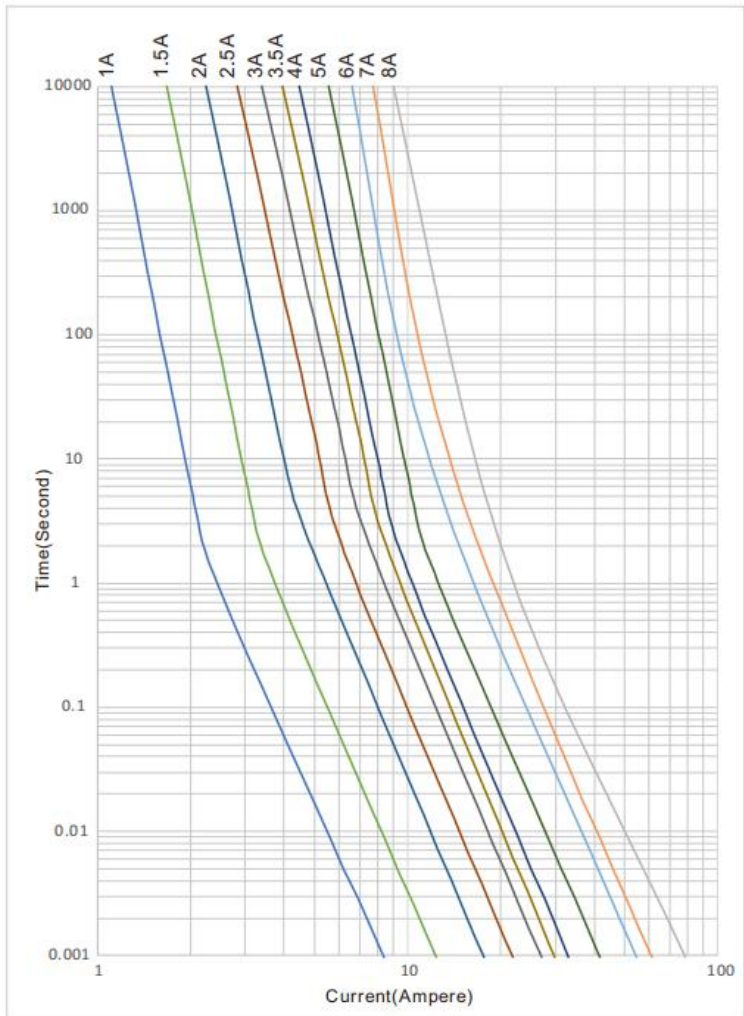
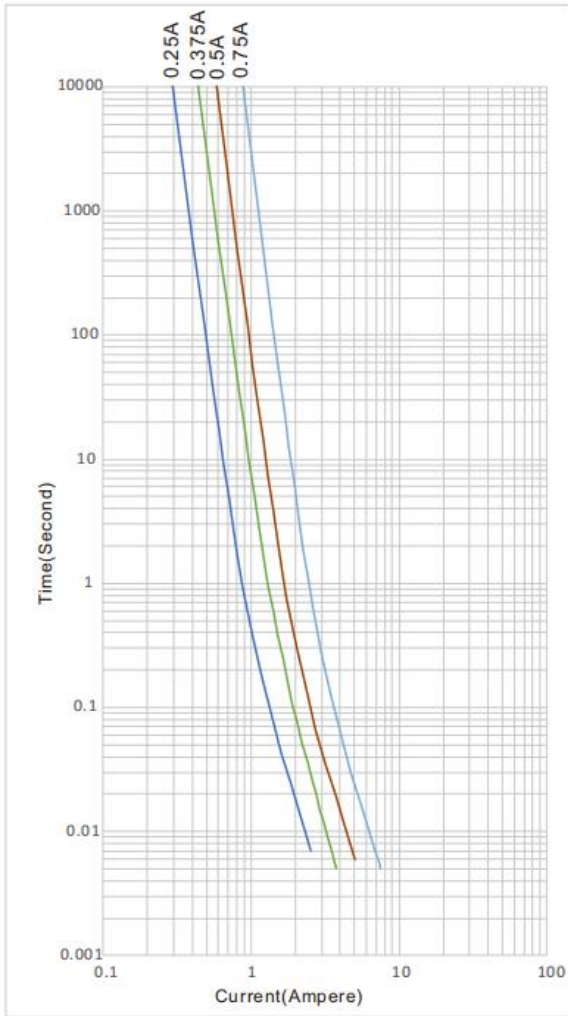

Packaging

5,000 pieces of fuses in plastic or paper taper

5000pcs)

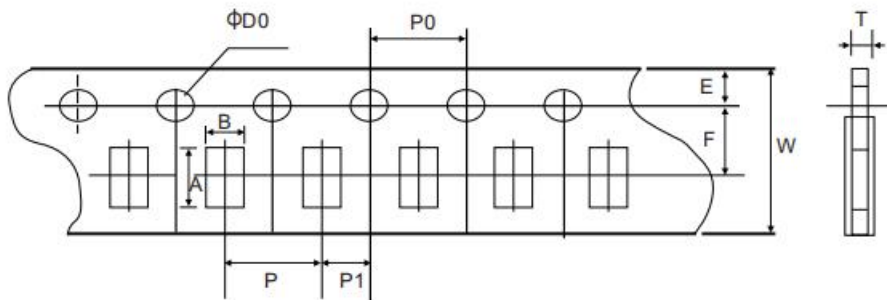

Symbol	Ao	Bo	Ko	Po	P1	P2
Spec	1.80±0.10	3.50±0.10	1.27±0.10	4.00±0.10	4.00±0.10	2.00±0.10
Symbol	E	F	Do	D1	W	T
Spec	1.75±0.10	3.50±0.10	1.50±0.10	1.00 (Max)	8.00±0.10	0.25±0.05